

Pacific Antenna Active Antenna Kit



Description

Our active antenna provides an amplified receive antenna giving performance equivalent to a much longer wire antenna.

It is useful for Ham, shortwave, AM broadcast, and low frequency (lower) reception.

It can also be used as a local sense antenna in a noise canceling diversity reception system.

Useful frequency range of approximately 100KHz to over 200Mhz.

Onboard 9V battery supply.

Push button power switch and LED power indicator.

Includes a 38 inch (96 cm) telescoping antenna.

Board Size 2.5 x 3.5 Inches (64 x 89mm)

Support

PACIFIC ANTENNA
QRP KITS.COM

qrpkits.com@gmail.com

Tools Needed

- Temperature Controlled Soldering Station with small tip or 15-35 watt soldering iron with small tip.
- Solder 60/40 or 63/37 Tin-Lead
- Small Diagonal Cutters
- Small Needle Nose Pliers
- Pencil, Pen, and/or Highlighter
- BRIGHT work light

Optional

- Magnifying headpiece or lighted magnifying glass.
- Multi-meter
- Solder Sucker or Solder Wick
- Small multi-blade Screw Driver
- Knife or Wire Stripper
- Small Ruler
- Cookie Sheet to build in and keep parts from jumping onto the floor.

Construction Techniques

- Please take time to inventory the parts before starting and report any shortages to QRPKITS.com
- Pre-sorting the resistors and capacitors can speed up the assembly and reduce mistakes.
- You can insert several parts at a time onto the board. When you insert a part bend the leads over slightly to hold the part in place, then solder all at the same time. Clip the leads flush.
- Most parts should be mounted as close to the board as possible.
- It is best to use a Temperature Controlled Soldering Station with small tip or a 15-35 watt soldering iron with small tip. Conical or very small screw driver tips are best.
- If you are a beginner, new to soldering, there are a number of resources on the web to help you get on the right track soldering like a pro. Google Soldering Techniques.

Here is one good example:

http://www.elecraft.com/TechNotes/NOSS_SolderNotes/NOSS_SolderNotesV6.pdf

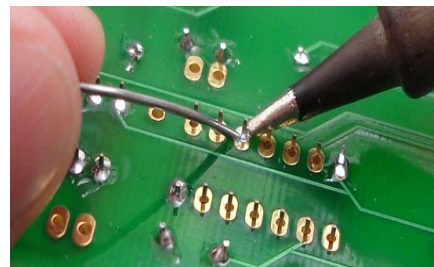
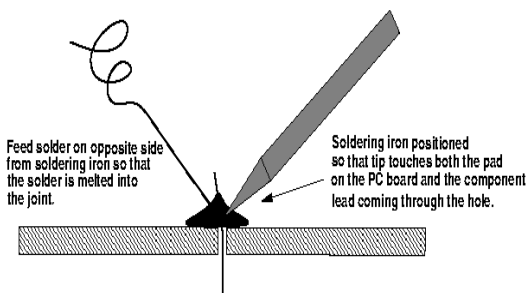

Parts

Use the photograph to help identify parts in your kit. Note that in some cases parts may vary slightly in appearance from those shown.

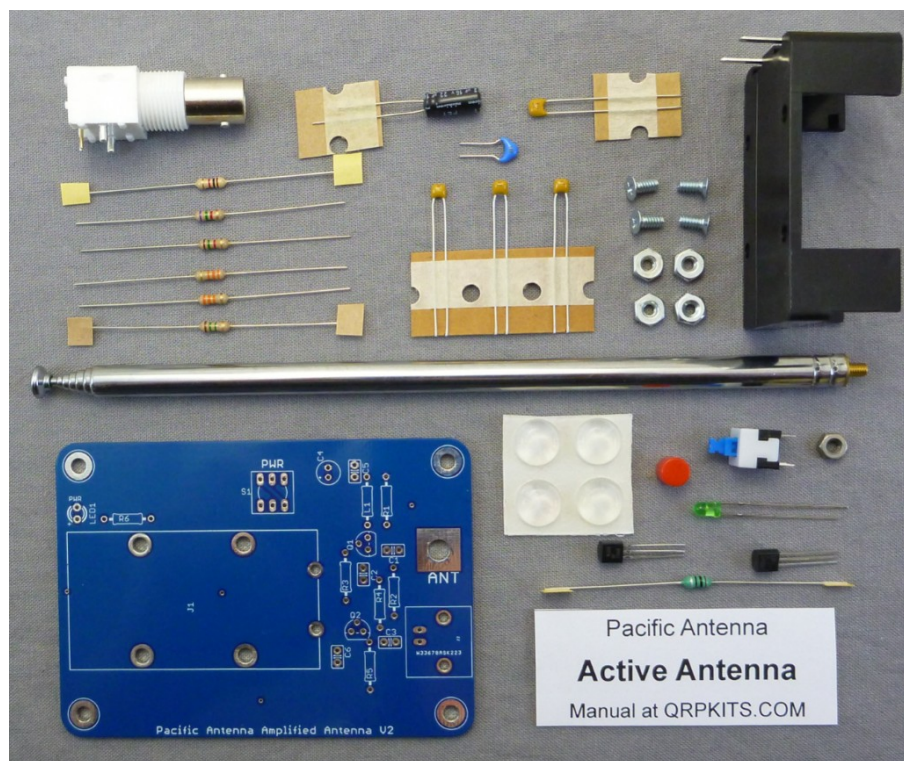

Parts Table

Check	Quantity	Part	Value	Description
	1	R5	1K	1/4W 5%, BRN-BLK-RED-GLD
	1	R2	1.5k	1/4W 5%, BRN-GRN-RED-GLD
	1	R6	7.5K	1/4W 5%, VIO-GRN-RED-GLD
	2	R3, R4	33K	1/4W 5%, ORG-ORG-ORG-GLD
	1	R1	1.5M	1/4W 5%, BRN-GRN-GRN-GLD
	1	C1	1000pF	Monolythic Capacitor Label 102
	1	C2	0.01uF	Monolythic Capacitor Label 103
	3	C3, C5, C6	0.1uF	Monolythic Capacitor Label 104
	1	C4	22uF	22uF Electrolytic Capacitor 16V or higher
	1	L1	10uH	Molded Inductor, BRN-BLK-BLK-SLV
	1	Q1	BF256	BF256 JFET in TO-92 package
	1	Q2	BC547	BC547 Transistor in TO-92 package
	1	LED1	3mm LED	Green body 3mm LED
	1	BNC	Output BNC connector	Board mount BNC
	1	S1	Push switch	8X8mm Pushbutton_Switch
	1	Cover	Push switch cover	Button cover, color varies
	1	J1	Battery Holder	9V Board mount battery holder
	4	Feet	Rubber feet	Rubber feet for PCB
	1	PCB	Circuit board	Amplified Antenna Circuit Board
	1	ANT	Antenna	Telescoping Antenna
	1	Nut	M3 nut	Nut for Antenna
	4	4-40 Screws	Flathead 4-40x1/4	Flathead steel screw, 4-40x1/4
	4	4-40 Nuts	4-40 hex nuts	4-40 steel hex nuts

Use the first column of the table below to check the parts as you inventory them and use the second column to check the parts as you install them.

Inserting the Parts

Install the components listed in the table.

For resistors, and diodes, you can preform the leads by bending them down at a 90 degree angle.

Match the distance from the body to the holes in the circuit board where the part will be located.

Once each part is installed, bend its leads on the bottom of the board to hold it in place, solder the leads and clip off the excess lead.

Resistors

Locate and install the Resistors R1, R2, R3, R4, R5 and R6 in the marked location on the board using the table below as a guide.

If any doubt of the color code, use a multimeter to determine the correct parts by measuring their resistance.

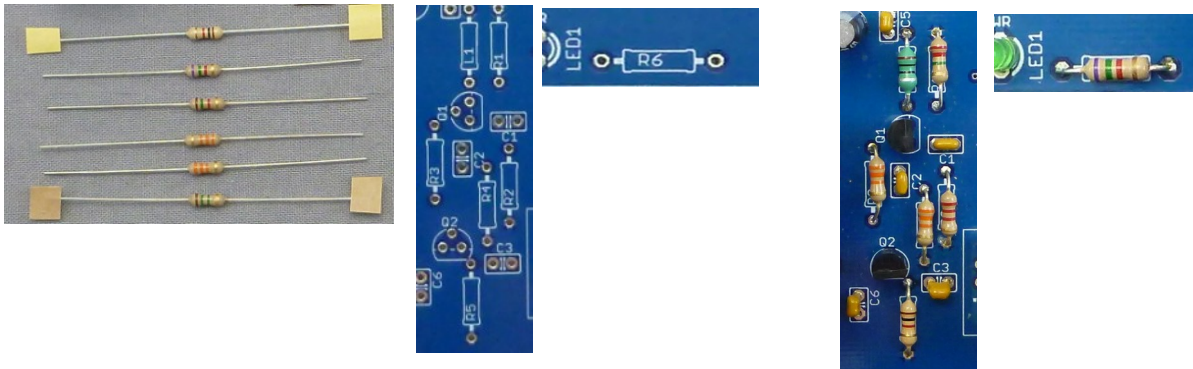

Resistor	Value	Color Code
R1	1.5M	BROWN-GREEN-GREEN-GOLD
R2	1.5k	BROWN-GREEN-RED-GOLD
R3, R4	33K	ORANGE-ORANGE-ORANGE-GOLD
R5	1K	BROWNN-BLACK-RED-GOLD
R6	7.5K	VIOLET-GREEN-RED-GOLD

Capacitors

Install the 0.001uf (1000pF, marked 102) monolythic capacitor C1 in the location marked on the board.

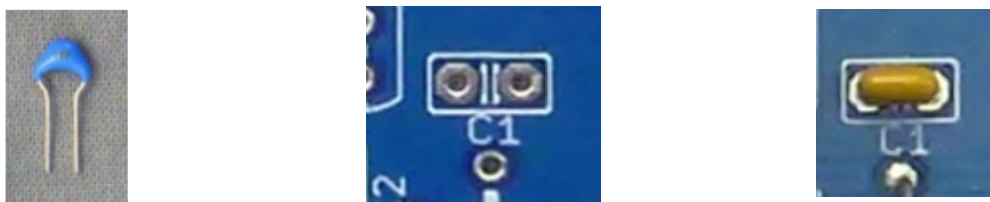

Note that C1 may have a brown or blue body depending on the supplier. Check the printed value on its body to confirm.

Next, install the 0.01uf (marked 103) monolythic capacitor C2 in the location marked on the board.

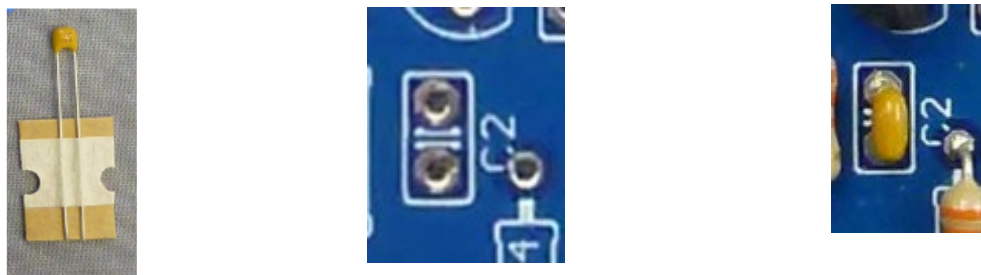

Now, install the 0.1uf (marked 104) monolithic capacitors C3, C5 and C6 in the locations marked on the board.

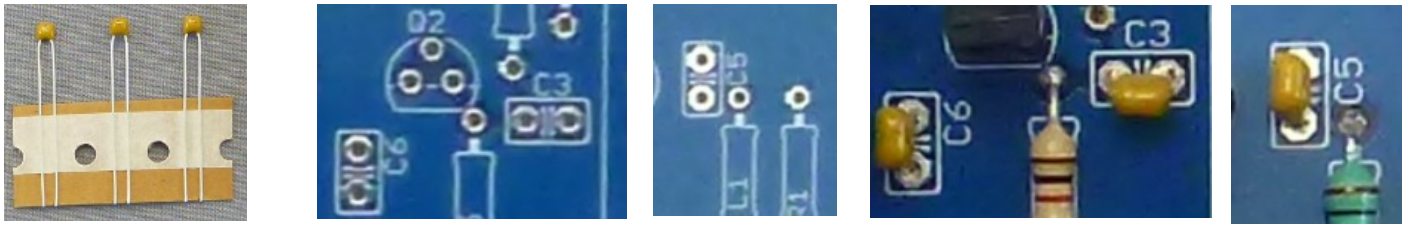

Locate and install the 22uf electrolytic capacitor C4 in the location marked on the board.

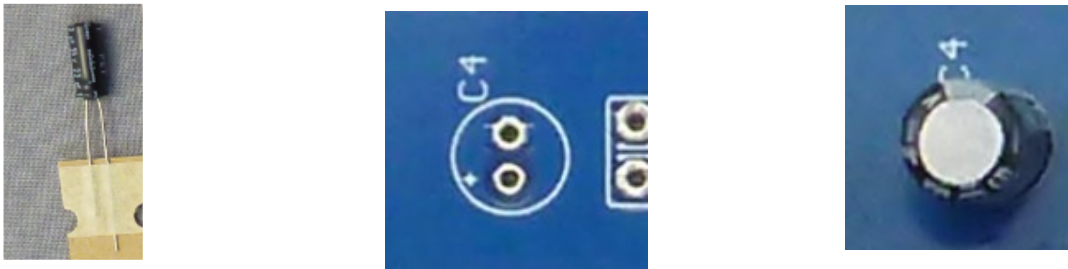

Note that it has one lead longer than the other. That lead goes in the hole with the “+” symbol next to it on the board. The opposite side of the capacitor body is also marked with a “-” to mark the negative lead side.

Inductor

Install the molded inductor L1 in the location marked on the board.

Note that this part is similar in appearance to a resistor but has a body that is usually tapered (thinner) in the middle and is usually a different color than most resistors.

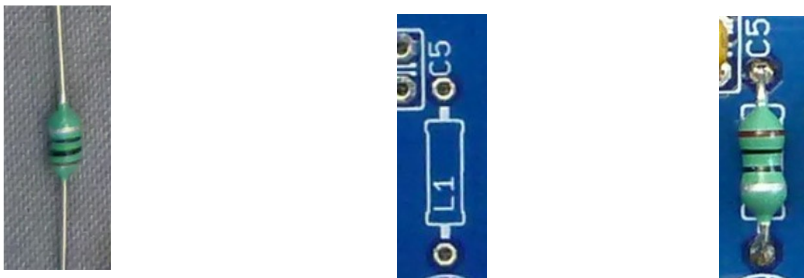

LED

Install the LED. It has specific polarity and must be installed only one way in the board or it will not work. It has one lead that is longer (the anode=+) and one shorter (the cathode)

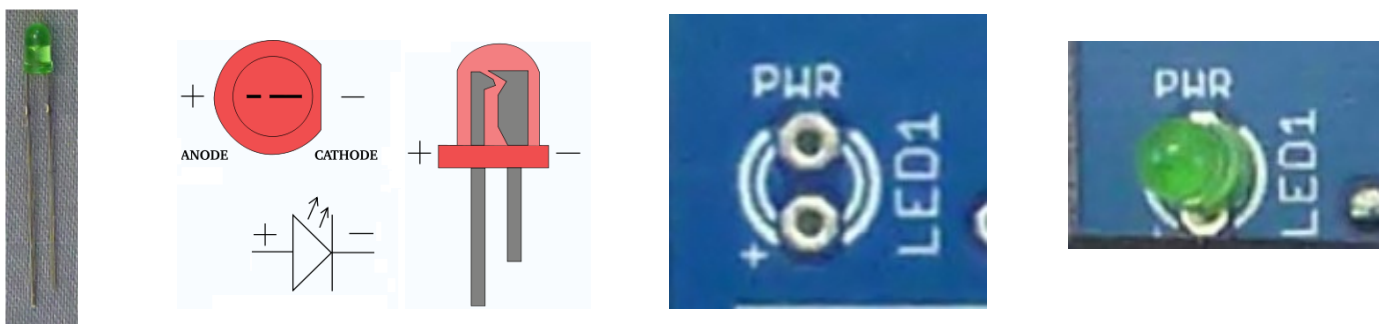

The body of the LED will also usually have a slight flat edge on the same side as the short (-)lead.

The circuit board has a “+” symbol next to one pad of the LED location. To install, insert the LED so that the long lead (+lead) goes into the hole with the “+” symbol next to it on the board and the shorter lead goes into the other hole.

Transistors

Install the BF-256 JFET transistor in the position Q1. This is a plastic TO-92 case part and it is static sensitive so use care in handling.

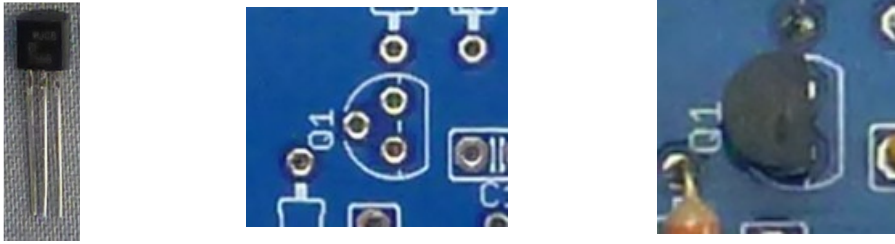

Note to orient the body of Q1 with the board layout. The center leg will need to be bent back slightly to go into the offset center hole in the board.

Next, locate and install the BC-547 bipolar transistor in the location Q2 on the board. This part is also in a black plastic, TO-92 case and is installed in the same way as Q1.



Power Switch

Locate and install the DPDT switch in position S1 on the board. This switch has 6 pins that fit into the holes in the board. The orientation of the switch does not matter.

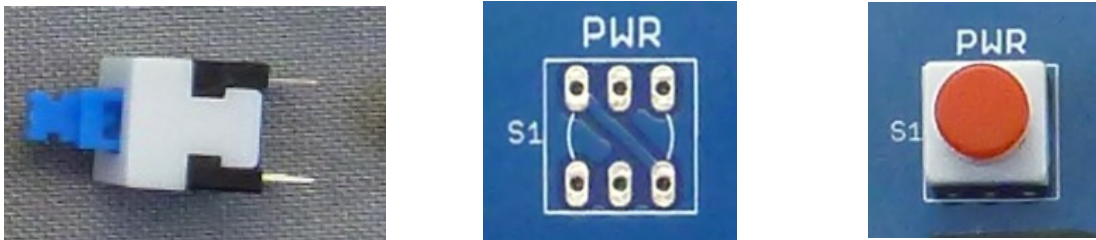

Solder a single pin first and check that the switch is seated on the board. If not, heat the soldered pin while pressing the switch into the board and hold it while the solder solidifies.

Repeat this with a pin on the opposite end of the switch. This will hold it in place while the other 4 pins are soldered.

Gently press the supplied button cap onto the blue switch shaft as shown above.

BNC

Note: If you plan to mount this kit in a case or build into another assembly where input and output connectors will not be needed or if you are using connectors to be mounted on the case you will not want to install the on board BNC connector.

Solder the supplied BNC connector on each end of the board in the position marked J2. Be sure that the connector is fully seated and both small leads extend through the board. Then solder the support pins one at a time.



After the first support pin is soldered, recheck that the connector is seated on the board. If not, reheat the connector support pin while pressing down on the board to fully seat it.

Once the connector is seated and both support pins are soldered, go ahead and solder the two signal connection pins (smaller) on the BNC.

Battery Holder

Locate and install the battery holder in the location J1 using the included flathead screws and nuts.

Once secured, with the screws, solder the two pins that provide power to the board.

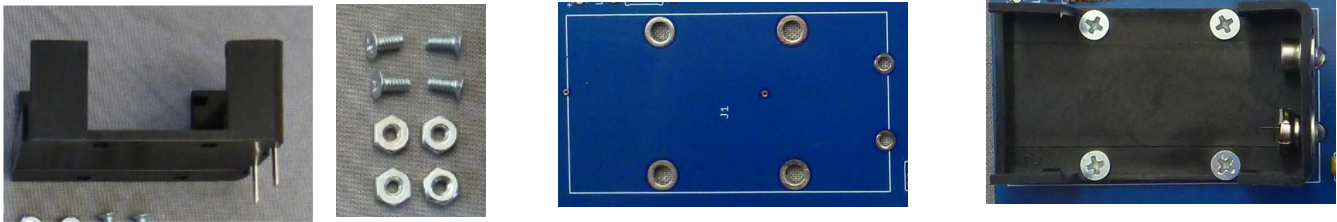

Rubber Feet

If the kit is not to be mounted in an enclosure, go ahead and install the 4 rubber feet to the bottom corners of the board where the holes are located.

This prevents shorts from metal surfaces and protects tabletops, etc from damage from the circuit board.

Congratulations, you have completed assembly of your Active Antenna kit!

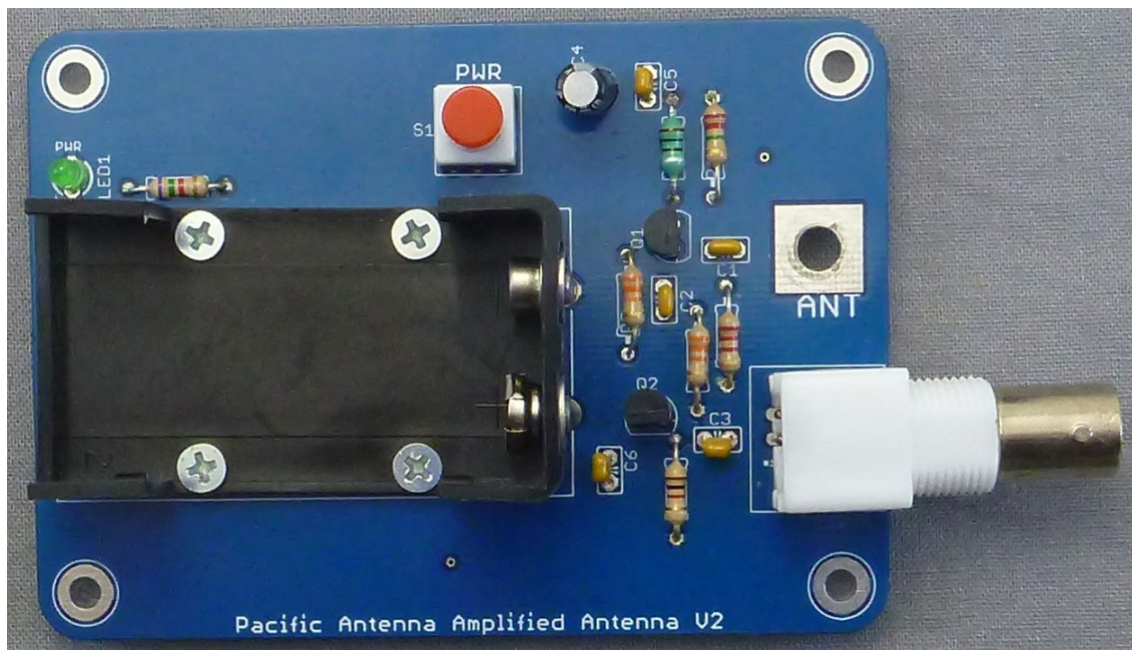

Checkout

Inspect the board for any bad solder joints, shorts or other problems and correct before use. Confirm for proper orientation of parts.

Install the telescoping antenna using the supplied nut in the location marked "ANT". Tighten the nut gently to secure the antenna in place.

Install a 9V battery and press the power switch. The led should light. If not, recheck solder joints and component placement.

Usage

Use a bnc adapter or cable to attach the active antenna to a receiver. If attaching to a transceiver, use care not to transmit into the active antenna as doing so will likely cause damage.

Turn on your receiver and tune to the band of interest. Press the power switch on the active antenna and you should hear a significant increase in background noise and possibly signals.

Tune the receiver and you should hear signals as you would with any other antenna.

While a short antenna is a compromise, an active antenna such as this can often equal performance of a wire antenna.

Performance of the active antenna can be improved by adding a short 3-5ft section of wire to the telescoping antenna. Just use a clip lead to attach the wire to the end of the telescoping antenna to extend its length.

Always turn off the power switch when not in use to avoid draining the battery.

Packaging

Packaging is left up to the builder. The kit can be used as is, built into another assembly or installed in a case.

Thank you for purchasing our Active Antenna kit!

Support: qrpkits.com@gmail.com

Board Layout

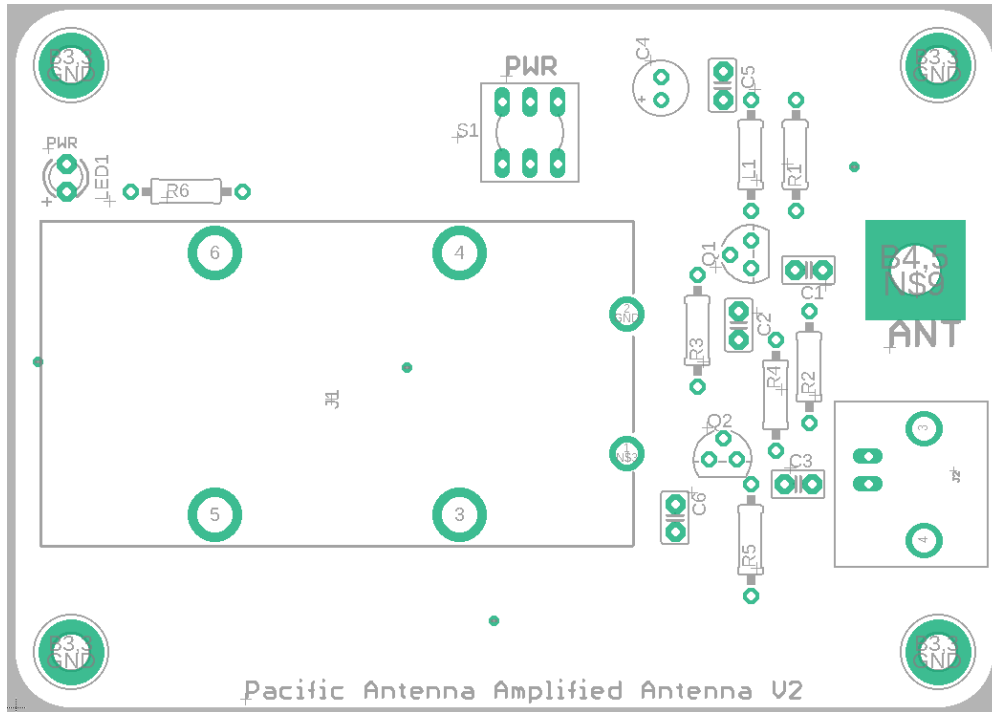

Schematic Diagram

